

**SET-UP / INSTALLATION INSTRUCTIONS**  
for SLACK CABLE BI-DIRECTIONAL SWITCH

04964-204

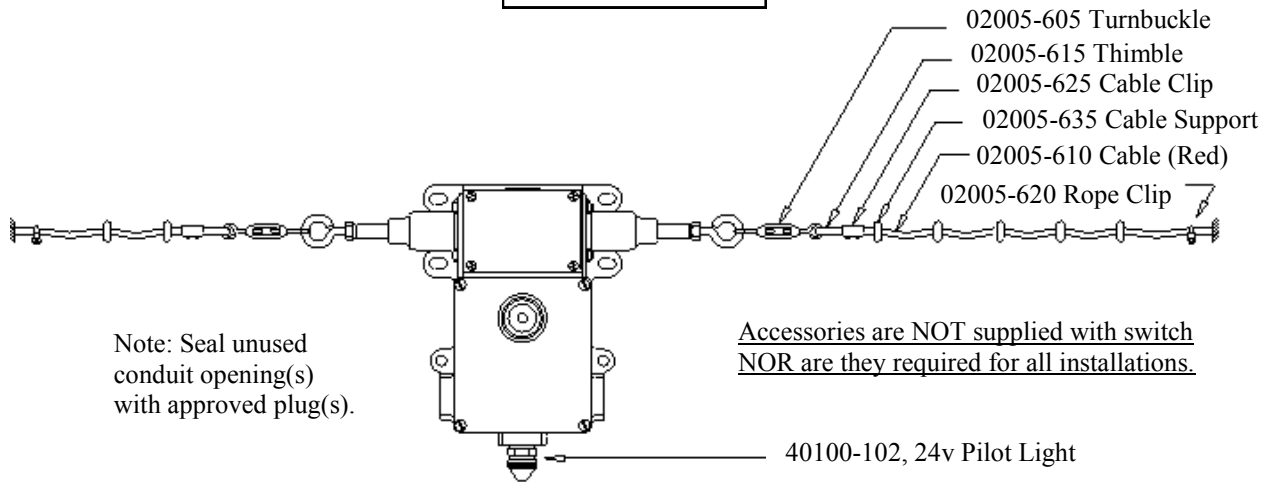

Since every installation is unique and separate, the following instructions can be considered flexible. There are some basic switch setup procedures that must be observed and they are indicated by the symbol (>). The balance of the suggestions and information is subject to change to accommodate those most familiar and responsible for the installation.

**INSTALLATION:**

1. Observe all SAFETY REQUIREMENTS and PROCEDURES during installation, set-up and running.
2. N.E.C. and local wiring codes MUST be followed at all times.
3. The cable switch MUST be mounted on a flat surface! (Recommend 1/4-20 Bolts torque to ~60 in./lb. ~69 cm-kg)
4. The first cable support SHOULD be located 6 to 12 in. (15 to 30 cm) from the switch. (see drawing on other side)
5. The first cable support SHOULD be located so that the cable is aligned with the switch shaft within 5 degrees.
6. It is recommended that the balance of the cable supports be spaced at intervals NOT exceeding 10 feet (~3m). Supports at properly spaced intervals are necessary to ensure that the cable weight will NOT affect switch operation.
7. The maximum recommended cable length is 200 feet (60.69m) in each direction and SHOULD be in as straight a line as possible.
8. Wiring SHOULD be through the motor control circuit. (See reference diagram below)

**SET-UP and USE:**

- > 1. Secure (2 cable clamps per end are recommended) and adjust the SLACK cable length in both directions so that there is sufficient “droop” or “swale” in the cable between cable supports.
- > 2. Push the blue “RESET” button to set the contacts.
- > 3. Pull the trip cable on one side of the switch or the other (but NEVER both sides simultaneously) to test and assure that the switch is functioning properly. Reset and test other side. Simultaneous pulling of the cables with equal force on both sides will NOT actuate the switch.
- > 4. After applying control circuit power then repeat step #(s) 2 & 3.
- > 5. NOTE: All cable material will stretch with use and/or temperature variations. If the switch is set-up during extreme conditions a re-adjustment will be necessary to ensure proper switch function.

**INSTALLATION:**

1. Regular Preventive Maintenance inspections are recommended.
2. Some conditions to watch for are:
  - a. Proper trip/reset tensions and slack within the trip cable.
  - b. Physical damage to the device.
  - c. Physical damage to the cable.
  - d. Frayed wiring.
  - e. Loose cable connections.
  - f. Any loose components.
  - g. Any worn components.
3. If other assistance is desired please contact the factory.

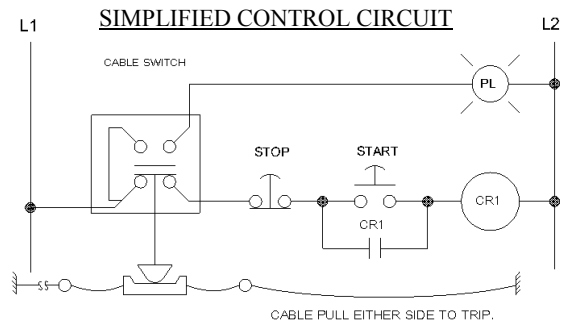

All wiring/components provided by user.

**REES, Inc. Fremont, IN 46737 260-495-9811 FAX 260-495-2186 www.reesinc.com**

## OPERATING SPECIFICATIONS

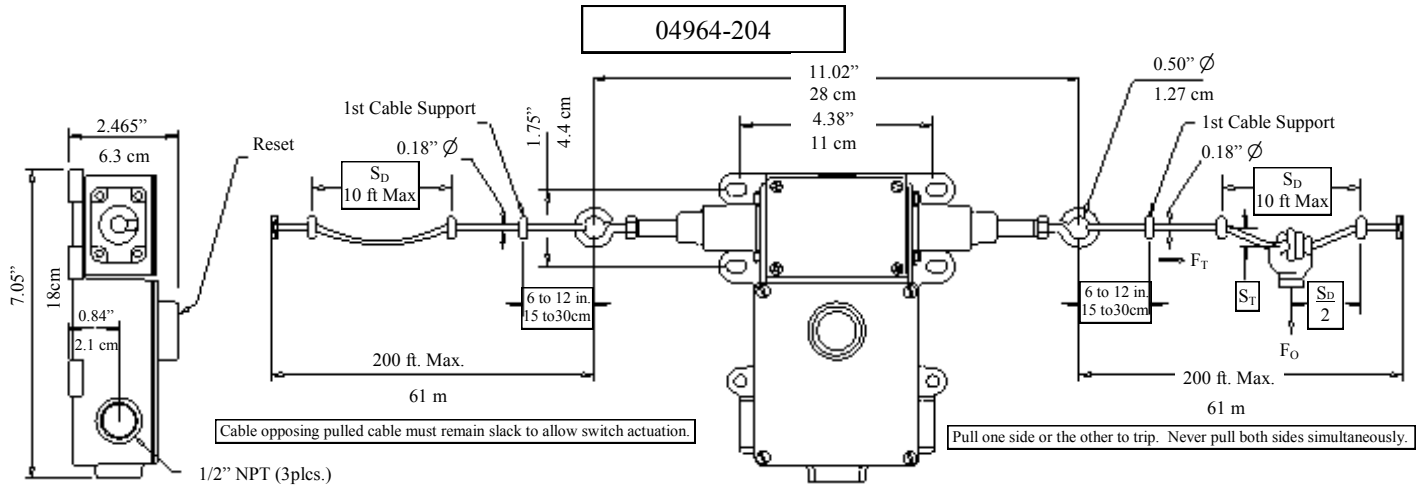

04964-204 shown with cable pulled. Cables should be slack when installed properly and not pulled.

$F_T$  = The value of force, along the cable, which trips the switch.

$F_O$  = The value of force, applied by the operator perpendicular to the cable, which trips the switch.

$S_D$  = The distance between the cable supports.

$S_T$  = The distance the cable is deflected at the time of tripping. \*  $S_T$  is in addition to any slack "droop" req'd for set-up.

Catalog Number	Contact Arrangement	Style	$F_{SU}$ Setup Force	$F_T$ Trip Force	$S_D = 5 \text{ ft.} / 1.5 \text{ m}$		$S_D = 10 \text{ ft.} / 3.0 \text{ m}$	
					$F_O$	$S_T$	$F_O$	$S_T$
04964-204	2 NO + 2 NC	Bi-Directional	None, slack	<u>52 lb.</u> 23.6 kg	<u>28 lb.</u> 12.7 kg	<u>4 in.*</u> 10.2 kg	<u>15 lb.</u> 6.8 kg	<u>9 in.*</u> 22.8 kg

CSA certified (File LR 3648);

CSA—C 22.2 No. 14-08;

IEC Ratings:

Utilization = AC 15, DC 13;

NEMA Ratings: AC = A 600; DC = N 300

Temperature: Operating = 0°C to +55°C (-32°F to +131°F);

Fusing Requirements: 10A Slow Acting; 16A Fast Acting

Mechanical Life Rating = 250,000 operations

Operating Position: Can be mounted in any position.

CSA-US (File LR 3648);

ANSI/UL 508;

CE marked;

EN 60947-5-1: 1997;

$U_e = 600 \text{ vAC}; U_e = 250 \text{ vDC}; U_i = 600 \text{ vAC}; U_{imp} = 2.5 \text{ kV}; I_{th} = 10\text{A}$

Storage = -40°C to +85°C (-40°F to +185°F)

Volts	A600 AC 15	
	Make	Break
24	60	6.0
120	60	6.0
240	30	3.0
480	15	1.5
600	12	1.2

Volts	N300 DC 13	
	Make	Break
24	2.2	2.2
125	2.2	2.2
250	1.1	1.1

### AVAILABLE ACCESSORIES:

02005-605	02005-610	02005-615	02005-620	02005-625	02005-635	40100-102
Turnbuckle Tension Adj.	Cable, Steel	Thimble, Strain Relief	Rope Clip Standard	Cable Clip Optional	Eye Bolt Cable Support	24 volt Pilot Light
